



2018 Late Model Rules

DISCLAIMER:

The rules and/or regulations set forth herein are designed to provide for the orderly conduct of racing events and to establish minimum acceptable requirements for such events. These rules shall govern the condition of all events, and, by participating in these events, all participants are deemed to have complied with these rules. *No expressed or implied warranty of safety shall result from the publication of or compliance with these rules and/or regulations.* They are intended as a guide for the conduct of the sport and in no way a guarantee against injury or death to a participant, spectator, or official.

The race director shall be empowered to permit reasonable and appropriate deviation from any of the specifications herein or impose any further restrictions that in his opinion do not alter the minimum acceptable requirements. *No expressed or implied warranty of safety shall result from such alterations of specifications.* Any interpretation or deviation of these rules is left to the discretion of the officials. Their decision is final.

On occasion when situations arise that are not covered by written rules, special rulings may be put into effect by the Series of Track Officials. Once such rulings are acted upon, they *may* be added to the existing rules and/or procedures.

Contact Info:

RUSH Racing Series Directors: Vicki Emig (724) 674-6100/Cell & Mike Leone (724) 967-2363/Cell
4368 US 422, Pulaski, PA 16143
724-964-9300 (phone) 724-964-0604 (fax)
E-mail: info@rushracingseries.com

Travis Harry (Competition Director): 814-676-9997 or 814-758-5737 (after 5 PM).
E-mail: travisharry1123@gmail.com

Website: www.rushlatemodels.com
Like us on Facebook at www.facebook.com/rushlatemodels
Follow us on Twitter @RUSHLM

The following specifications shall be considered the "Official Rules and Specifications" for all events sanctioned by the RUSH Dirt Late Model Series.

All event procedural rules will fall under the RUSH Touring Series for Touring Series events or individual track procedural rules if classified as a RUSH Weekly Series event.



Championship Series

Sweeney Chevrolet Buick GMC "Weekly Series Championship" (\$5,000 to-win paying 40 positions): Must be a Weekly member to be eligible for points and point fund monies. Drivers can compete at any RUSH-sanctioned event and accumulate points from March through September. Drivers best 12 point scores will be utilized (best two per week Monday through Sunday).

"Track Pack Bonus Program" (\$300 to-win paying cash to top 5 & contingencies to 6-8 at each weekly-sanctioned track that pays either a one-year or three-year sanction fee): Must be a Weekly member to be eligible for points and point fund monies. RUSH point system used for all member racers at all events March through September.

Pace Performance "Summer Chase" (\$3,000 to-win paying 10 positions): Top 10 Weekly member drivers at each RUSH weekly-sanctioned speedway (RUSH point system) and top 10 in Touring Series Driver Points through June 25 will be eligible. Drivers can compete at any RUSH-sanctioned event and accumulate points from June 29 through Labor Day (Touring members must also be Weekly members to count Weekly events). Standings will be determined by average points per event score plus 0.5 point per night competed over 6 (adds on to average point score). Drivers must compete in a minimum of six events. (Note: finishes will continue to count towards Weekly Series Championship as well.)

Sweeney Chevrolet Buick GMC "Touring Series" (\$5,000 to-win paying 12 positions): Must be a Touring member to be eligible for points and point fund monies. Points accumulated at each Marquee Event. Drivers can use Platinum Events to replace 1 missed Marquee Event and up 3 worst Marquee finishes (2 if using 1 as a replacement event) (Please see Touring Series Rules & Procedures for more info.) Although it would not be the intention of the Series, in the event of unforeseen extreme circumstances Touring point fund could be adjusted.

"Futures Cup" (\$500 to-win paying 10 positions): Must be a Weekly member, not be older than 19 years of age, and not be a prior "Futures Cup" Champion to be eligible for points and point fund monies. Those 18 & 19 cannot have more than 1 prior season of Crate Late Model experience (8 or more events = 1 season). No headlining division experience permitted. Those under 16 should verify eligibility to race at each individual track. Points are based off Weekly Series Championship plus the addition of possible stand-alone TBA event(s).

Point System: The following system will be utilized for all of the above programs: 1. 100 2. 98 3. 96 4. 94 5. 92 6. 90 7. 89 8. 88 9. 87 10. 86 11. 85 12. 84 13. 83 14. 82 15. 81 16. 80 17. 79 18. 78 19. 77 20. 76 21. 75 22. 74 23. 73 24. 72 25 & any other starter 71. Drivers attempting to race, but not starting the feature will receive 70 show-up points. Note: Excluding the Touring Series, at each event drivers will receive a car count bonus of 12 points provided there are 12 or more cars signed in. If there are less than 12 cars, the car count bonus will be based on number of competing cars signed in.

Postponed feature events will revert back to the weekend they were initially scheduled for with the exception of an event that has been pushed to the following year.

Membership Fees: \$125 to become a Weekly Series Member and \$125 to become a Touring Series Member OR \$225 for both. MUST be a member to be eligible for above programs and \$100,000 excess participant accident insurance. Policy period is 1/1/18-1/1/19; however, coverage does not begin until membership is completed and paid. RUSH insurance benefits will cover the member driver after the tracks participant accident limit and driver's individual health insurance benefits are exhausted, but only at RUSH-sanctioned events.

POINTS ARE NOT RETROACTIVE. YOUR POINTS WILL NOT COUNT UNTIL MEMBERSHIP IS COMPLETED & PAID! Drivers that do not wish to become RUSH members, MUST complete the Non-Member Registration. RUSH Weekly Series Member Tracks have the ability to mandate membership in order to compete. In this case, drivers have the ability to purchase at temporary membership (available at speedway) at the cost of \$25 per event. Once driver purchases 5 temporary memberships, driver will become a full Weekly Series member with points and insurance benefits starting effective immediately. Points and insurance benefits are not retroactive.

RUSH reserves the right to decline a membership or revoke a membership at any time.

Awards Banquet/Point Funds/Tie-Breakers: A RUSH Racing Series Awards Banquet will be held at the conclusion of the season (mid to late January). Drivers/Car Owners are expected to attend or have a pre-determined representative to accept awards. Unclaimed payoffs and awards will be mailed at a later date.

In the event of a tie for any of the above championships, tiebreaker will be determined by the driver with the most wins (high point scores for Weekly & Chase) followed by most second place finishes, etc. until the tie is broken. If a tie happens in any other position, the tie will remain with point fund monies added up between the tied positions and split equally.

AGE REQUIREMENTS:

Age requirements vary by speedway. It is the team's responsibility to verify eligibility regardless if's a Touring Series or Weekly Series event.

PAYOFF:

While the RUSH Series makes every effort to sanction and/or schedule events at reputable facilities, and has never had any problems with purse payouts to competitors, please be aware that RUSH cannot be responsible in the event that a promoter fails to make purse payments, or pays with checks which are later found to be not negotiable. This notice includes the possible situation where a promoter might pay the full purse to RUSH with a check that is later to be insufficient. RUSH will not pay purse payments until promoter's check clears. When speedway and/or promoter's check clears, RUSH will then guarantee proper purse payments, subject only to resolution of protests, or technical infractions.

RUSH Series Officials reserve the right to hold payoff(s) of driver(s) selected for technical inspection(s). Payoffs will only be released to 1099 recipient(s) of selected driver(s) upon final technical inspection results and/or appeal process providing said inspection complies with RUSH Technical Rules. In the event selected driver(s) technical inspection results does not comply with RUSH Technical Rules and appeals process has been exhausted, said payoff will be adjusted and distributed to other competing racers.

RUSH Series Officials also reserves the right to withhold a driver's payoffs in the event said driver has a debt to the Series.

RUSH will mail the person or corporation designated on the membership form any purse or point fund payoffs. In the event of a car owner change, a new membership form must be completed. In the event of a car owner change midseason, point fund payoffs would be prorated based on performance (based on the program's specs, i.e. best 12 finishes or # of races run during Summer Chase) in all point funds other than Touring, which has a separate driver/owner point fund. A Form 1099 MISC by January 31 of the following year will be sent to the person or corporation that earned a minimum of \$600.00 during the year for any monies paid by Great Crate Racing Northeast, LLC D/B/A RUSH Racing Series, as required by the IRS.

SERIES' SPONSOR PRODUCT CONTINGENCIES AND DECALS:

The RUSH Late Model Series decal is required on both sides of the car. Recommended location: outer spoiler vertical blades. Sponsor decal package/logos link for body graphics usage is located at the bottom of the website sponsor page.

Required RUSH Series sponsor decals must be displayed prominently on both sides of the car at all events. Your car may be checked for decals at any time.

Certain product manufacturers award contingency product and/or money. The awards are dependent upon the manufacturers decal being displayed on the racecar. To be eligible to receive the award from the manufacturers concerned, it is your responsibility to ensure that the correct decal is affixed to your racecar.

Please be aware that the Series' has no responsibility to pay the award, but only to provide the participant with the certificate previously agreed upon and contracted with the Manufacturer.

Contingency prizes will be awarded to the car owner of record. It is the responsibility of the participant to redeem contingency prize certificates and/or product by expiration date on certificate. Series will not be responsible for delivery and/or transportation of contingency prizes that were not available for pick-up on event date.

Keep in mind that sponsors only put money into the Series to gain exposure for their products; no exposure will eventually mean no money and smaller championship programs.

RUSH Racing Series Officials may refuse to allow a participant to compete in an event if it is determined at their discretion that any advertising and/or sponsorship or similar agreement is **detrimental** to the sport, the RUSH Racing Series, or the event promoter for any reason, including the image of the sport.

CONDUCT:

1. **General** - All drivers crew chief, car owner, crew member and/or team representative agree to act in a professional manner as determined by RUSH Officials. The professional manner includes, but is not limited to verbal representation, written representation, any representation that may represent the RUSH Racing Series, sport of Late Model racing and/or motorsports in general and/or any affiliates. Verbal abuse may result in an immediate disqualification from the event. Repeated violation(s) may also warrant fine and/or suspension.
2. While we recognize your right to express opinions, good or bad, on social media, drivers and crew members should be advised that threats against officials, other drivers or crew members will not be tolerated. Any action by a driver or crew which appears to be the execution of a threat will result in penalties via suspensions and/or fines against the driver and/or car owner. The driver or car owner will be held responsible for the actions or members of his or her crew.
3. Any driver/owner that disparages RUSH in any publication (including messages boards, social media, etc.) may be suspended for a minimum of one event and/or fined.
4. All drivers must arrive at Series races in a timely manner so that they may participate in the entirety of the racing event.
5. No driver will be permitted to compete and/or participate while under the influence of any alcoholic beverages and/or illegal substances. If a driver is found to be participating in such a manner, an immediate suspension will be invoked.
6. Any driver, during an event; a competitor, crew chief, car owner, crew member and/or team representative may be requested to report to the RUSH Command Center for consultation with RUSH officials. The request may be communicated over the one-way radio and/or verbally. Failure to comply with the request will be subject to fine and/or suspension and/or any other action deemed appropriate by RUSH Officials.

Participants grant and assign to RUSH Racing Series, its affiliates and RUSH Racing Series Sponsors the non-exclusive rights and authority to use my image and likeness, including my name, nickname, initials, picture, photograph, animation, persona, autograph/signature (including facsimiles thereof), voice, biographical information, and/or any and all other identifying characteristics, including the image of my vehicle, whether portrayed in still or action pictures, drawings, or other artistic renderings, in connection with my participation in RUSH Racing Series Events and for any and all uses or purposes that publicize and promote RUSH Racing Series or any of its affiliates in any way in any and all media or formats.

ENVIRONMENTAL WARNING:

1. Any driver, car owner or crewmember found to be altering, by means of contaminating the racing surface or pit area or racing entrances and/or staging or technical inspection areas or ANY part of the event grounds or properties and nearby driveways will be disqualified. The local authorities and/or agencies may be notified and the violator(s) and their information may be turned over to these authorities at that time.
2. No race cars or vehicles including, but not limited to race trailers, or support vehicles or trailers will be allowed to carry or conceal, in marked, unmarked or using any form of misrepresentation of jugs or bottles or carrying devices of any type (with concerns to chemicals), for the purpose of altering, conditioning or changing a tire's baseline settings (from its original factory set baseline settings) will be allowed in or around the/any RUSH Series Event(s). All local authorities and applicable agencies may be called and the violators and their information will be turned over to these authorities at that time.

TECHNICAL RULES & REGULATIONS

It is ultimately the obligation of each participant to ensure that their conduct and equipment complies with all of the applicable rules, as they may be amended from time to time; any amendments supersede any previous rules regarding any technical and/or aspect. An amendment is effective upon the date of the publication of the amendment regardless of when a competitor receives the actual notice.

Any new components, including engine components, suspension components, body designs, frame designs and/or components of any type utilized in competition must be approved by RUSH Officials prior to being introduced into competition.

ENGINE:

1. GM part number 19258602 or 88958602 & GM part number 19318604 or 88958604.
2. All engines are to remain sealed from the factory. These engines are sealed at the intake manifold, cylinder heads, front cover, and oil pan with special GM twist-off bolts. The original factory seals, bolt type, must remain unaltered. Tampering, removal, or modifications of any type and/or broken factory seals, bolt type, will not be permitted and will result in an immediate disqualification from the event (loss of points and money). The engine may be impounded immediately for further inspection.
3. The exception to this will only be if a repair or rebuild is required. The repair/rebuild must be authorized by the RUSH Racing Series and/or Crate USA, at which time the engine may be repaired or possibly rebuilt per the guidelines set forth in the GM Technical Manual #88958668. Crate engines must not be altered, modified, or changed from factory specs.
4. In the event of a repair or rebuild only a RUSH or Crate USA authorized rebuilder facility may install permitted seal tags on engine. RUSH and Crate USA Generation III (yellow) & Generation IV (green) seals allowed. **NO RM bolts, FASTRAK, NDRA, DIRTcar (red or blue), Crate USA Generation I (silver) or Crate USA Generation II (blue) seals permitted.** *For any other sealing system, contact RUSH for approval.*
5. Engines "must" be sealed in all of the above stated locations with either the "original" GM twist off bolt heads, RUSH seal tags, Crate USA seal tags, or a combination of the "original" GM twist off bolts and/or RUSH or Crate USA seal tags.

6. The sealed engines must remain intact and not be tampered with; **any seals** that have been tampered with, removed, or modified, and/or broken will make the engine illegal and will result in an immediate disqualification from the event (loss of points and money). The engine may be impounded immediately for further inspection. Modifying any internal engine parts or changing the parts from stock as delivered sealed from the factory will result in disqualification for the night's event (loss of points and money), loss of all Series points to date in the division the infraction occurred in, suspension from all RUSH-sanctioned Series competition for 365 days, fined \$1,000, and an indefinite probation; penalties apply to both driver and car owner.
7. In the event a repair must be made to an engine scheduled to compete in consecutive RUSH-sanctioned events or if RUSH seals cannot be obtained in time for competition in a single event, engine owner and or competitor "must" have authorized RUSH engine rebuilder of their choice contact RUSH Series Directors to receive permission and instructions on obtaining "approved" temporary seals in order for engine to compete. RUSH Competition Director can also install "approved" temporary seals in this situation. Temporary seals will "only" be permitted on repaired engines for events that are designated by RUSH Series Directors. Note: Once temporary seals are removed from engine, they must be immediately returned to the RUSH Racing Series Office.
8. The permitted GM factory sealed crate engines must not be altered, modified, or changed from the GM specifications set forth in the GM Technical Manual #88958668; no changes are allowed to the engine- intake manifold, heads, valve covers, front cover, oil pan, harmonic balancer, or any other part or parts on or in the engine.
9. After much research RUSH Series officials, along with GM Officials, have determined on some cases that original factory cylinder heads and valve springs do not meet the required correct install height. To correct this, shimming will be allowed to meet the correct install heights listed in the chart below. These updates will be published in a forthcoming version of the GM Technical/ Specification Manual.

Valve Spring Specifications – New				
Description		88958602	88958603	88958604
Valve Spring P/N		10212811	12551483	12551483
Valve Spring P/N -set of 16		n/a	12495494	12495494
Diameter (+/- .010")	(A)	1.250"	1.340"	1.340"
Free Height (+/- .015")	(B)	2.021"	2.154"	2.154"
Installed Height (Ok to shim to proper height)	(C)	1.70"	1.780"	1.780"
Pressure @ Installed Height (+/- 5 lbs)	(D)	80 lbs.	110 lbs.	110 lbs.
Open Height	(E)	1.270"	1.300"	1.300"
Open Pressure (+/- 10 lbs)	(F)	195 lbs	270 lbs.	270 lbs.
Coil Bind	(G)	1.20"	1.21"	1.21"
Wire Diameter		.177"	.178"	.178"

10. **New Beehive (blue) Valve Springs:**

Valve Spring Specifications – New (Blue) Beehive Valve Spring		
Description	Engine	19318604
Fast Burn Cylinder Head		19300955
Valve Spring P/N -16		12625033
Valve Spring P/N –Retro Conversion Kit		19300952
Diameter Top (+/- .008")		1.060"
Diameter Bottom (+/- .008")		1.270"
Free Height (+/- .015")		2.122"
Installed Height (Ok to shim to proper height)		1.780"

Pressure @ Installed Height (+/- 5 lbs)		98 lbs.
Open Height		1.300"
Open Pressure (+/- 13 lbs)		264 lbs.
Coil Bind		1.210"
Wire Diameter		Ovate

11. No vacuum pumps.
12. Engine's GM serial number and when applicable RUSH or Crate USA build certification number must be clearly visible to Series' or track technical inspectors.
13. RUSH Racing Series Officials reserve the right to inspect, exchange and/or confiscate any GM Crate engine, or other specified engine component. Refusal to surrender an engine or other engine part for inspection, exchange or confiscation, will result in disqualification for the night's event (loss of points and money), loss of all Series points to date in the division the infraction occurred in, suspension from all RUSH-sanctioned Series competition for 365 days, fined \$1,000, and an indefinite probation; penalties apply to both driver and car owner.
14. ANY VIOLATION OF THE ENGINE RULES AND/OR FACTORY SPECS INSIDE THE SEALING SYSTEM OF THE ENGINE WILL result in disqualification for the night's event (loss of points and money), loss of all Series points to date in the division the infraction occurred in, suspension from all RUSH-sanctioned Series competition for 365 days, fined \$1,000, and an indefinite probation; penalties apply to both driver and car owner.

After the suspension period, the driver and/or car owner can only compete in Series events with an engine equipped with original factory GM sealing bolts, RUSH, and/or permitted Crate USA seals.

For subsequent violations in regard to any illegal modification to any GM Performance Parts Crate Engine, an indefinite suspension may be issued.

15. Any violation of the engine rules and/or factory specs outside the original GM twist off bolt heads and/or permitted Series seal tags on the engine will result in the driver and car being disqualified from that event (loss of points and money). Multiple infractions outside the sealing system will result in the penalties stated in the "Multiple Infractions" section of the rules.

ENGINE SETBACK:

1. A maximum of 25 ½"-inches from the center of the ball joint to the front of the motor plate/engine bell housing flange

ENGINE SELECTION/PROTEST:

1. Any RUSH-sanctioned race track and/or RUSH Series Director(s) are authorized to call for an engine inspection or tear down *at any time*. Tear down and inspection will be performed by RUSH Tech/Competition Director. If this happens, Track/Series will remove engine at race track and impound until inspection day can be arranged for all parties involved. (See paragraph number five for procedures if selected car is to race in successive events.)
2. The protest fee for a complete teardown of an engine that finishes the A main in the top five is \$2,000, and must be made by a driver/owner that finishes in the top five. \$300 of protest fee will go to Series or Track and the remaining \$1,700 will go to the winner of the protest.
3. The protest fee for a partial tear down of an engine that finishes the A main in the top five is \$1,500, and must be made by a driver/owner that finishes in the top five. \$300 of protest fee will go to Series or Track and the remaining \$1,200 will go to the winner of the protest. A partial tear down will include the following: cam profiled along with the timing components, lifters, and cylinder heads verified.

4. Protest and fee in cash must be made to a RUSH Tech Inspector, Race Director, or Track Tech Inspector within 15 minutes of the checkered flag of the feature. Protest cannot be withdrawn once it has been declared.
5. At any time an engine is protested and driver/car owner accepts protests and agrees to tear down, the engine being protested must be removed immediately and impounded by Series/Track. Protested engine will be sealed by RUSH Official or person(s) appointed by RUSH to insure that it has not been tampered with, and to verify engine's identity. Any refusal to permit engine confiscation will result in disqualification for the night's event (loss of points and money), loss of all Series points to date in the division the infraction occurred in, suspension from all RUSH-sanctioned Series competition for 365 days, fined \$1,000, and an indefinite probation; penalties apply to both driver and car owner.
6. *If the protested car wishes to race in successive RUSH-sanctioned events within 72 hours (three days) the following will apply ONLY at the discretion of RUSH:* RUSH Series Officials reserve the right and also grants the right to RUSH-sanctioned speedway tech officials to seal or otherwise identify the protested engine to allow the car to compete in successive events within 72 hours (three days). Further postponement of tear-down will be at the discretion of RUSH Directors/Officials. The driver and/or owner has the option whether to surrender the engine on the night it's protested or have it identified and retained for the successive races. However, if the driver chooses to compete with the engine after its selection for tear down, and that engine is found to be out of compliance with RUSH Technical/Engine rules, the driver will be disqualified from all races entered after the engine was protested, in addition to the race when engine was protested. RUSH *may* assess penalties for each race in which the selected engine was used after its selection, if it is found to be illegal. If the engine is found to comply with all applicable rules, then driver/owner will be awarded all money and points earned for each event.
7. At this time, the feature finish will be frozen until inspection is complete. In the event of a disqualification, finishing position, points and monies would be adjusted accordingly.
8. Failure and/or refusal to tear down an engine and/or for your race car to be inspected by Series at any time will result in disqualification for the night's event (loss of points and money), loss of all Series points to date in the division the infraction occurred in, suspension from all RUSH-sanctioned Series competition for 365 days, fined \$1,000, and an indefinite probation; penalties apply to both driver and car owner.
9. Inspection location will most likely be at RUSH office/garage located at 4368 Route 422, Pulaski, PA 16143. Although other inspection locations could be selected. There will be no dispute over RUSH Official's choice of location.
10. Driver and/or car owner and one other representative of the team will be allowed in the tech area during the engine teardown. Only one representative from the team protesting the engine will be allowed in the tech area during the engine teardown. Additional attendees must be approved by RUSH pursuant to a written request. Protestor and protested driver and/or car owner along with the confiscated sealed engine and/or parts must be present at predetermined location. All parties must remain present during the entire teching procedure.
11. Note: All removed original GM Bolts, RUSH and/or CUSA Seals must be returned immediately to the RUSH Office.
12. Engine infractions "within the bolts" will result in disqualification for the night's event (loss of points and money), loss of all Series points to date in the division the infraction occurred in, suspension from all RUSH-sanctioned Series competition for 365 days, fined \$1,000, and an indefinite probation; penalties apply to both driver and car owner.
13. In the event that the series confiscates engine, for inspection, and said engine is found to be legal, and comply with the all the rules, the "Series" will provide a full GM gasket set, and the seals to reassemble engine at no charge to the authorized rebuilder and engine owner. If engine is protested by another racer for inspection, the engine owner is responsible for all expenses required for reassembly.

CARBURETOR:

1. One four-barrel carburetor only. The 604 and 602 Chevrolet Performance Circle Track engines perform best with a quality 650 CFM Carburetor. Any 750 CFM or smaller carburetor allowed; must have 1 11/16" base plate maximum.
2. All carburetors in competition must retain conventional style floats along with needles and seats. Maximum allowed fuel pressure is 12 psi.
3. Engine must be naturally aspirated.
4. **604** - May use one carburetor spacer (1" - one piece with 0.040" tolerance maximum) and two standard paper gaskets (maximum 0.070" thick), one gasket between intake to spacer and one gasket between spacer to carburetor. Carburetor spacer may not protrude down into intake manifold.
5. **602** - May use one carburetor spacer (2" - one piece with 0.040" tolerance maximum) and two standard paper gaskets (maximum 0.070" thick), one gasket between intake spacer and one gasket between spacer to carburetor. Carburetor spacer may not protrude down into intake manifold.
6. Pipe plugs must remain in manifold heat crossover port on GM 602 crate engines.

DISTRIBUTOR/IGNITION:

1. Any electronic distributor-type ignition system. NO crank trigger, distributor less multi-coil, or magneto ignition system. No programmable ignition box. Only one ignition box permitted. Dual pickup distributor permitted; only one pickup in distributor can be utilized.
2. Competitor may be asked for electronic ignition at any time to be sent for testing and inspection. Failure to relinquish electronic ignition will result in disqualification and "refusal of tech" penalties.

BATTERY/STARTER:

1. Maximum one 16-volt battery. No lithium batteries.
2. Battery not permitted to be located in the driver's compartment/cockpit.
3. All battery supports and/or mounts must be secure and braced in two (2) horizontal positions and one (1) vertical position.
4. The battery terminals must be insulated and enclosed with a non-conductive material that will prevent contact with any part of the race car should the battery become dislodged from the battery mount.
5. All cars must have a starter in working order.

WATER PUMP:

1. Cast or aluminum permitted.
2. No electric water pump. No electric fan.

EXHAUST:

1. Collector-type headers required. Must have four (4) tubes into one (1) collector of a consistent diameter.
2. NO tri-y headers, merged headers, or square-tube headers allowed.

3. Mufflers not required unless track mandates. *When mandated, mufflers must have some type of internal noise dampening characteristics, baffles, extruded holes, screen, chambered, etc. Mufflers must meet local speedway's noise decibel requirements. External mufflers only.*

FUEL CELL/FUEL PUMP:

1. All cars must have fuel cells that meet and/or exceed FT3 or SFI 28.3 specifications. The fuel cell must not exceed a 35-gallon capacity.
2. The fuel cell must be enclosed completely in a container that is a minimum thickness of 20-gauge magnetic steel and/or .060"-inch aluminum.
3. The entire container must be visible for ease of inspection.
4. The fuel cell must be mounted behind the rear axle between the rear tires, a minimum of 4"-inches ahead of the rear bumper. The bottom of the fuel cell must not be any lower than the bottom of the rear end/quick change housing.
5. The fuel cell must be mounted with a minimum of two (2) .125" inch thick, minimum 2" width steel straps. Straps must fully encircle the fuel cell. Fuel cells that are mounted in a square tubing frame will be permitted. A minimum of 7/16"-inch ASTM Grade 8 bolts must be used to mount the fuel cell to the frame.
6. The fuel pick up must be positioned on the top of the fuel cell and be constructed of steel. The fuel pick up must have a check valve. Pickups on vertical sides prohibited.
7. For the purpose of inspection, the driver and/or crew must be prepared to drain fuel upon request for inspection and/or measurement.
8. Mechanical fuel pumps only; cam driven or belt driven style. Regulators permitted. Fuel injection system(s) and/or electrical fuel pumps and/or any type of pressurized fuel system will not be permitted.

FUEL:

1. Only Sunoco Racing Fuel - Standard (commonly referred to as 110 and/or purple) or RUSH '91' will be the specified fuels permitted for competition in RUSH Racing Series sanctioned events. (Note: there will be a 2-race burn-off of 2016 legal fuels at newly RUSH weekly-sanctioned speedways.) Additives and/or blending of any type including; methanol, alcohol, nitrous oxide, propylene oxide, nitro methane or other performance enhancing chemical additives will not be permitted. NO mixing of the Sunoco 110 & RUSH 91. Fuel may be tested from time-to-time and/or submitted for verification by designated RUSH Racing Series and/or Track Officials to Sunoco Race Fuels. **It is the racer's responsibility to know what he or she is putting in the fuel cell.**
2. Series reserves the right to check fuel anytime. Three samples will be taken by RUSH or Track Official. Each sample will be identified as sample #1, sample #2, and sample #3. Sample #1 will be retained by Series and sent to lab; sample #2 will be given to selected fuel's driver/owner; and sample #3 will be retained by Series to be utilized as a tie-breaker in the event any issues may occur with samples #1 & #2. In the event driver/owner chooses to send sample #2 to be analyzed, RUSH must approve selected lab. Fuel samples not conforming to RUSH Late Model Series Fuel rule will be deemed illegal.
3. **PENALTIES FOR FUEL VIOLATIONS:** Disqualification from event (loss of points and money) in addition to the following penalties:
 - First Offense: \$500 fine & 30-day suspension from any RUSH-sanctioned event plus all related lab testing costs.
 - Second Offense: \$1,000 fine & 90-day suspension from any RUSH-sanctioned event plus all related lab testing costs.
 - Third Offense: \$2,000 fine & 365-day suspension from any RUSH-sanctioned event plus all related lab testing costs.

ROLL CAGE & FRAME:

1. The minimum wheel base is 103" with a maximum wheel base of 105".
2. All frames must be fabricated from magnetic steel with a minimum of 2"-inches x 2"-inches or approved rectangular magnetic steel with a minimum material thickness of .083"-inches. Note: Aluminum, titanium or other 'exotic' material is not permitted on any part of the frame.
3. A minimum of 1.75" Outside Diameter magnetic steel tubing, 4130 Chrome Moly or DOM with a minimum material thickness of .083"-inches, will be permitted for frames that are fabricated from round tubing.
4. Rear bumpers that are stubbed may only extend a maximum of 8"-inches beyond the frame. Any stubbed rear bumper that extends further than the maximum of 8"-inches must be formed and directed 8"-inches toward the front of the car.
5. External rub rails will not be permitted.
6. It is recommended that all cars be equipped with a tow hook and/or strap for the purpose of towing.
7. All battery supports and/or mounts must be secure and braced in two (2) horizontal positions and one (1) vertical position.
8. All cars must have a roll cage fabricated from a minimum of 1 1/2" outside diameter with .065-inch seamless magnetic steel tubing.
9. The side roll bars and/or door bars must extend into the door panels.
10. A minimum of three (3) bars must be utilized on the left side of the car in the door area.
11. Any of the bars that are utilized for the top portion of the roll cage, included, but not limited to the front and rear hoops, the top hoop, and the uprights, must extend a minimum of 1"-inch above the driver's helmet.
12. A stone shield for remote oil filters or transmission is allowed, maximum 24" x24" located near rear engine plate.
13. Any frame built on or after January 1st, 2006, must have the builder's unique serial number plate prominently attached to the left side roll cage upright. The plate must be welded in place. All characters on the plate must be a minimum of 1/2"-inch in height and the serial number must not exceed 8 characters.

DRIVER SIDE INTRUSION PLATES:

1. A minimum 1/8" (.125") thick magnetic steel intrusion plate on the driver's side door bars is HIGHLY RECOMMENDED and will be mandated effective January 1, 2019.
2. Approved installation:
 - A. Welded plates- Individual plates between door bars are permitted but must be weld around the perimeter of each opening. Minimum area covered is 16 inches by 26 inches.
 - B. A minimum of 16" x 26" plate bolted to fabricated 1/8" (.125") magnetic steel tabs, welded securely to the chassis, using a minimum of eight (8) x 3/8" Allen button head bolts. A minimum of three (3) fabricated 1/8" (.125") magnetic steel tabs and 3/8" Allen button head bolts required across top of the intrusion plate, a minimum of three (3) fabricated 1/8" (.125") magnetic steel tabs and 3/8" Allen button head bolts required across the bottom of the plate, and one (1) fabricated 1/8" (.125") magnetic steel tabs and 3/8" Allen button head bolt in each in the middle front and middle rear of intrusion plate.

- C. A minimum of 16" x 26" plate bolted to a minimum of six (6) approved-design door bar clamps using the included 12 x 1/2" Allen button head bolts per the manufacturer's specification. A minimum of three (3) approved-design door bar clamps and the included six (6) x 1/2" Allen button head bolts required across top of the intrusion plate and three (3) approved-design door bar clamps and included six (6) x 1/2" Allen button head bolts required across bottom of intrusion plate. Vendor and part number must be clearly labeled on part.

Current approved-design door bar clamps – in order of submission:

- Bicknell Racing Products – Part Number: BRP 9547
- Wehr's Machine & Racing Products – Part Number: WM397
- Allstar Performance – Part Number: ALL4198
- (No other manufacturer has submitted a design for approval at this time)

TRANSMISSION/DRIVELINE AND DRIVELINE COMPONENTS:

1. Direct drives systems of any-type will not be permitted.
2. The transmission must be bolted to the engine it must have forward and working reverse gear(s) and must be able to shift to forward or reverse with engine running.
3. All cars must be equipped with a working self-starter.

DRIVESHAFT:

1. The driveshaft must be a minimum of 2"-inches in diameter. All drive shafts must be painted white.
2. Only one (1) drive shaft connected from the transmission to the center section of the rear end will be permitted.
3. A minimum of one (1) driveshaft hoop / sling must be fastened securely to the frame. It is recommended that two (2) driveshaft hoops / slings be used.
4. Ballspline transmissions are strongly recommended to run carbon fiber driveshafts only! (This is for your safety.)

REAR END:

1. Live-axle type rear ends will not be permitted.
2. Independent rear suspensions will not be permitted.
3. Floater-type wide-five hub assemblies will be the only hub assemblies permitted.
4. The axle housing must be of the "closed tube" design utilizing "full floating" magnetic steel axle shafts.
5. The center section of the axle housing must be manufactured of either aluminum or magnesium.
6. Axle tubes must be one (1) piece. Axle tubes must be manufactured of aluminum or magnetic mild steel. Axle tubes manufactured of exotic, heavy materials will not be permitted. The outside diameter of the axle tubes must not exceed three (3) inches. Axle tube internal inserts or external sleeves will not be permitted. The addition of any ballast weight to the axle housing will not be permitted.

STEERING COMPONENTS:

1. Only one (1) power steering pump allowed.
2. Electronic steering or electronic steering components will not be permitted.
3. All cars must be equipped with a quick-release-type steering wheel that is a full circle.

BRAKES, BRAKE COMPONENTS, WHEEL HUB:

1. Brake calipers must be manufactured of aluminum.
2. The brake caliper including brake caliper pistons must be used as produced by the brake caliper manufacturer.
3. Brake rotors must be manufactured of magnetic or stainless steel.
4. Brake rotors must be used as produced by the brake rotor manufacturer.
5. Wheel hubs must be manufactured of aluminum or magnesium.
6. Wheel hubs must be used as produced by the wheel hub manufacturer.
7. The combined weight of the wheel hub, wheel bearings and seal, spindle nut and washers, brake rotor and attaching hardware, the axle cap, and the wheel spacer must not exceed 27 pounds.
8. No brake floaters permitted.

WHEEL, WHEEL DISCS, WHEEL SPACERS:

1. Only aluminum wheels will be permitted, maximum wheel width 14". Must be mounted with lug nuts, no knock-off or center lock wheels.
2. Only steel wheel cover fasteners will be permitted. It is "highly recommended" that wheel discs are wheel discs that are fastened to the wheel using a minimum of three (3), 1/4 or 5/16 inch diameter magnetic steel hex head bolts.
3. Only aluminum wheel spacers will be permitted. Wheel spacers must not be fastened to the wheel.
4. The combined weight of the wheel, wheel hardware, wheel disc and fasteners, and tire must not exceed 40 pounds. *The maximum combined weight in this rule is based upon current tire rules and may need to be adjusted in the event of an alternate tire.
5. Bleeder valves of any kind will not be permitted.

TIRES:

1. Hoosier RUSH/USA 25 and USA 55 stamped Crate Racin' USA and shoulder plated tires will be durometered; RUSH/USA25 must punch 46 or harder when checked cold, and USA55 must punch 60 or harder when checked cold.

RUSH will allow a "simple" re-groove and/or sipe ONLY on the factory pre-molded cross marks found on each individual block of the RUSH/USA25 tires. The groove is not to exceed the pre-molded marks. A #1 or #2 grooving head and blade is recommended. Be advised that these grooves may not extend into the sidewall of the tire.

There is to be NO siping (other than the pre-molded cross marks) or needling of the RUSH/USA25. Light buffing is permitted, but MUST be done in a manner as to NOT create a sipe (cut/split) in the surface of the rubber. Note: Small cuts that are not consistent with a buffing pattern MAY be acceptable. Rule of thumb: If you can see it, it's too deep; if you can feel it, it's way too deep. (See the tech official for a ruling before competition).

Grooving and siping is permitted on the Crate Racin' USA D55.

Altering tires by any means of needling or chemical treating is strictly prohibited!

Burn-off: Newly-sanctioned speedways will be permitted a burn-off period for previously allowed tires determined by Series Directors. (Note: Speedway(s) and/or Series Officials have the ability to mandate the USA55 on the right rear if track conditions warrant; i.e. Raceway 7 mandates the USA55 on the right rear.)

2. **WARNING:** RUSH, Crate Racin' USA and Hoosier Racing Tires strictly forbids any chemical alteration of the tire carcass and/or tread compound such as tire soaking or use of tread "softener". RUSH, Crate Racin' USA and Hoosier Tire strictly forbids the physical defacement (removal, altering, or covering) of tire sidewall markings in any manner. Failure to comply with this warning could result in premature or catastrophic tire failure and may result in serious injury or death.
3. Series may take physical samples and/or use the "Sniffer" to insure that no competitor has employed any chemicals to alter the performance of his or her tires. At the sole discretion of race officials, any competitor may have his or her tires tested with the "Sniffer" for both internal and external introduction of chemicals or be required to allow samples to be taken for later submission to an independent laboratory, or both. Three samples will be taken per selected tire; samples will be taken by RUSH or Track Official. Each sample from selected tire will be identified as sample #1, sample #2, and sample #3. Sample #1 will be retained by Series and sent to lab; sample #2 will be given to selected tire's driver/owner; and sample #3 will be retained by Series to be utilized as a tie-breaker in the event any issues may occur with samples #1 & #2. In the event driver/owner chooses to send sample #2 to be analyzed, RUSH must approve selected lab. Tire samples not conforming to manufacturer's submitted factory benchmark will be deemed illegal.
4. It is the driver's responsibility to know what is on their race car at all times. Any used wheels or tires that may be suspect by the driver should not be used. The driver or a crew member may be in the tech area to view what is being tested, but **will not** be allowed to view "the sniffer" readings. That information is the sole property of RUSH and driver will be notified if they pass or fail.
5. If "the sniffer" determines there is an unapproved chemical presence whether inside the tire, wheel, or outside the tire or wheel, driver(s) will be disqualified for the remainder of the racing event. Tire(s) in question will be confiscated and driver and/or car owner may be fined and could be suspended at Series Officials' discretion. Driver and/or car owner will be notified in writing of decision. All decisions are final.
6. Any tire thought to be physically defaced or altered will be confiscated. While tire is in question, all money and points for that driver will be held until a ruling is made final. Any tire deemed to have been physically defaced or altered will result in disqualification from the event (loss of money and points) along with the following:

PENALTIES FOR ILLEGAL TIRES:

- First Offense: \$500 fine & 30-day suspension from all RUSH-sanctioned events plus all related lab testing costs.
- Second Offense: \$1,000 fine & 90-day suspension from all RUSH-sanctioned events plus all related lab testing costs.
- Third Offense: \$2,000 fine & 365-day suspension from all RUSH-sanctioned events plus all related lab testing costs.

Failure to allow any tire(s) to be confiscated will result in additional \$500 per tire fine in addition to any other fines and penalties. All decisions are final.

WEIGHT:

1. GM crate engine #1925806 or 88958602 – 2200 lbs. with driver (1-lb per green flag lap burn off in the feature only)
2. GM crate engine #19318604 or 88958604 - 2350 lbs. with driver (1-lb per green flag lap burn off in the feature only)
3. Bilstein Bandits Championship Program participants:
 - a. GM crate engine #1925806 or 88958602 – 2175 lb. with driver (1-lb per green flag lap burn off in the feature only)
 - b. GM crate engine #19318604 or 88958604 - 2325 lbs with driver (1-lb per green flag lap burn off in the feature only)

4. Any car that is found light at the scales following qualifying/time trials will lose its time and start from the rear of a heat. Any car that is light at the scales following a heat race, B main/consy, or feature will be disqualified from the event. The track scales will be considered the official scales for the event.
5. Weights up to 50 lbs. must be positively fastened by **two** (2) 1/2-inch diameter, minimum grade 5 bolts with a minimum of two (2) weight clamps. Threaded rods will not be permitted. No weights may be attached to rear bumper. Weight must be painted white with car number displayed. Penalty for losing attached weight on the race track is disqualification from the event competing in.
6. No driver-operated weight adjustment devices.

STANDARD LATE MODEL SUSPENSION:

1. Standard Late Model suspensions only. No spring loaded or shock-type 4-bar rods. Only standard solid 4-bar rods allowed. No torsion bar front or rear suspension. Sway bar ok. No brake floaters permitted.
2. Standard Late Model suspension equals one (1) shock per wheel except on left rear. Left rear is allowed two (2) shocks; one in front of rear end, and one behind rear end. Shocks must be mounted vertical to axle tube, not horizontal.
3. No shock to be utilized as a droop limiter; chains only; under slung bar type permitted. Droop limiting chain may have between the links a device using urethane or rubber biscuits as long as biscuits are visible and not contained inside a housing device.
4. One mechanical traction device allowed, either a lift bar or a pull bar. Only one (1) "wrap-up" shock, defined as a shock that damps axle wrap, is allowed with a pull bar. If a lift bar device is used instead of a pull bar, a "wrap-up" shock may NOT be used in addition to the lift bar's coilover shock.

Springs:

1. ONLY coil springs or leaf springs will be permitted. No pneumatic springs, hydraulic springs, "air" springs, or "air" shocks permitted. A shock that produces in excess of 175 lbs of rod force when compressed to center to center of the shock mounts measurement at the car's static ride height is considered a "spring" and is illegal.
2. Coil springs must be manufactured from magnetic steel. Leaf springs must be manufactured from either magnetic steel or approved composite material.
3. Stacked springs will not be permitted. Only one spring per shock; no dual, concentric, which is defined as a spring contained within the diameter of another spring, or stacked springs on any shock. Traditional take up springs will be permitted providing they carry no functioning rate (must be able to compress by hand) A progressive rated spring will be permitted.
4. Only solid material bump stops permitted; rubber, urethane, and plastic. No coil spring or valve spring-type bump springs permitted. No convex disc bump spring permitted. No pneumatic or hydraulic bump stops permitted.
5. Spring preload adjustments for coil springs must be made using mechanical adjusting nuts on the shock body.
6. Spring preload adjustments for leaf springs must be made using a mechanical adjusting device such as an adjustable shackle or threaded rod type mount.
7. Other than spring damping by the shock absorber, hydraulic, pneumatic, or electrically controlled adjusting devices, (static or dynamic) that affect spring preload or race car heights will not be permitted; "air dump" devices are not permitted.

Shocks:

1. Shocks, at any position on the race car including lift bar or torque arm shocks, must be constructed of magnetic steel or aluminum. "Thru rod" style shocks are NOT permitted. Remote reservoirs are permitted. Each shock may have a maximum of two external adjustment mechanisms. External reservoir may only have one external adjustment. Adjuster mechanisms may not be hidden by the rod end. All adjusters must be located on the shock body, on the shock rod, or on the remote reservoir; cockpit adjustment are NOT permitted.
2. NO remote adjustment of shocks is permitted, including electronic adjustment whether hard wired or wireless. Shock/Damper devices that are or can be referred to or defined as an "inertor" or referred to or defined as a "j-damper" are not permitted anywhere on the car.
3. Shock absorbers may not contain any "internal" spring that functions as a load bearing suspension spring, "internal" coil bump spring above or below the working piston, nor "internal" bump stop of any kind.
4. No pneumatic springs, "air" springs, or "air" shocks permitted.
5. Shock covers permitted, but must be removed for all technical inspections.

PENALTIES FOR ITEMS LISTED UNDER STANDARD LATE MODEL SUSPENSION, SPRING & SHOCK VIOLATIONS:

Disqualification from event (loss of points and money) in addition to the following penalties:

- First Offense: \$500 fine & 30-day suspension from any RUSH-sanctioned event plus any testing costs, if required
- Second Offense: \$1,000 fine & 90-day suspension from any RUSH-sanctioned event plus any testing costs, if required
- Third Offense: \$2,000 fine & 365-day suspension from any RUSH-sanctioned event plus any testing costs, if required

RUSH BILSTEIN BANDITS SHOCK "OPTION":

Cars must be equipped with RUSH Bilstein Bandits on all four corners; one shock, per wheel permitted to receive weight break. Cars found with non-RUSH Bilstein Bandits Shocks must weigh under standard shock rule weight or will be disqualified from the event. *Note: It is the driver's responsibility to notify Officials that he/she is competing with the RUSH Bilstein Bandits Shock package in order to receive weight break.*

The part numbers that may be used are:

RUSH RF 12-2, RUSH RF 9-3, RUSH LF 2.5-2.5, CR USA LF 2.5-2.5, RUSH LB 5-3, CR USA LB 5030, RUSH RR 3.5-1.5, CR USA RR 3.5-1.5, RUSH LRF 2.5-2.5, CR USA LRF 2.5-2.5, RUSH LRF 0-6, CR USA LRF 0-6, RUSH LRB 3-6, CR USA LRB 3-6, RUSH LRB 3-9, CR USA LRB 3.9, RUSH7 16-2. (Note: Shocks are sold individually.)

Bilstein Bandits Weight Rule:

- a. GM crate engine #19258602 or 88958602 – 2175 lbs. with driver (1-lb per green flag lap burn off in the feature only)
- b. GM crate engine #19318604 or 88958604 - 2325 lbs. with driver (1-lb per green flag lap burn off in the feature only)

In order to further insure that all competitors are racing on unaltered shocks, competitors agree to allow race car to be inspected by RUSH and/or Track Officials at any time and for any reason, and agree to immediately relinquish any one or all shock(s) from any position or all positions on his or her race car to tech officials as a swap. Competitor

must accept from tech officials a shock(s) of the same valving part number in return for the shock(s) relinquished. Refusal of a driver to accept the "swap" will disqualify the driver from the night's events.

Shock covers permitted, but must be removed for all technical inspections.

Shocks may not be altered in any way; shock shafts may not be shortened nor strategically bent to seek a handling advantage, gas pressure must not have been altered, and no tampering with the pistons, seals, oil, shock body or valve stack is allowed. RUSH Late Model Series competitors agree to willingly relinquish any shock that comes into question to RUSH Late Model Series tech officials for dyno testing and inspection to determine whether it is, or is not, a legal, unaltered shock. Shock(s) confiscated for further testing will be tagged by a numbered wire seal with Bilstein part numbers and wire seal numbers and documented on the official RUSH Shock Confiscation Form.

If, upon dyno testing and inspection, it is determined that the gas pressure, seals, piston, oil, shock tube, rod, or valving has been altered in any way, the shock absorber will be determined illegal and driver will be disqualified; loss of points and monies from the event.

Rear Suspension and Suspension Components:

1. Axle Housing, Rear Differential

- The axle housing must be of the "closed tube" design utilizing "full floating" magnetic steel axle shafts.
- The center section of the axle housing must be manufactured of either aluminum or magnesium.
- Axle tubes must be one (1) piece. Axle tubes must be manufactured of aluminum or magnetic mild steel. Axle tubes manufactured of exotic, heavy materials will not be permitted. The outside diameter of the axle tubes must not exceed three (3) inches. Axle tube internal inserts or external sleeves will not be permitted. The addition of any ballast weight to the axle housing will not be permitted.

2. Axle Housing Mounts/Birdcages

- The only materials used to fabricate axle housing mounts (birdcages) that will be permitted is aluminum or magnetic mild steel. Axle housing mounts fabricated of exotic, heavy materials will not be permitted.
- Standard one piece bird cages; no split bird cages. When fabricating axle housing mounts detail must be paid to functionality. The completed axle housing mounts, when comparing the right and the left side, must be as similar in design as possible.
- Swing arm and/or Z-Link suspension are permitted. The shock on the swing arm or z-link rear suspension must be mounted to the bird cage or bottom radius rod. Top and bottom solid rod links must be mounted on heims and run in the opposite direction of bird cage.

3. Rear Suspension Attaching (Radius) Rods

- The only materials used to fabricate attaching (radius) rods that will be permitted are magnetic steel or aluminum
- Aluminum attaching (radius) rods may be solid or tubular material. Magnetic steel attaching (radius rods) must be tubular with a maximum wall thickness of 3/16 inch.

Remote Control Suspension Devices:

1. No "in-cockpit driver controlled" suspension devices permitted. No weight jacks of any kind; this includes fifth (5th) coil, etc. Any driver using "in-cockpit driver controlled" suspension devices or weight jacks will be disqualified from competition. A competitor found with a remote control suspension device will be disqualified from the event (loss of points and monies) and forfeit the device permanently.

EXOTIC MATERIALS:

NOTE: All exotic materials are illegal, which includes titanium, tungsten and/or carbon fiber. EXCEPTION: As noted above, carbon fiber driveshafts are legal for safety purposes along with magnesium rear end center section, bells, and rear cover. No other magnesium parts will be permitted.

Driver Compartment:

1. Driver's seat must remain on the left side of the driveline.
2. A full metal firewall fabricated from magnetic steel and/or aluminum must encompass the driver's compartment from front to rear on both sides and floor boards.
3. Any edge and/or sheet metal end in and around the driver's compartment must be protected with trim and/or beading and rounded. Sharp and protruding edges will not be permitted.
4. Support bars that block the right window from the driver exiting the cockpit will not be permitted
5. A substantial rock guard with a minimum of three (3) window bars must be mounted in "front" of the driver. The rock guard must be made from wire or screen. Windshield screens must be a minimum of .090 inches and must be securely fastened.
6. A rock guard (Lexan screen) can be no higher than 4"-inches and no farther back than the front edge of the "right" side of the head rest.
7. A clearly marked electrical engine shut off switch within the reach of the driver.
8. Roll bar padding mandatory. Other cockpit padding, knee and steering pads recommended. All padding must be fire resistant.
9. Window nets certified to SFI Spec 27.1 or safety nets certified to SFI Spec 37.1 are highly recommended and shall be installed and used in accordance with manufacturer's instructions.
10. Driveline U-Joint scatter shields are recommended.
11. It is highly recommended cars be equipped with 10-lb fire suppression system meeting SFI 17.1 requirements.

BODY (See body diagram at the end of Rulebook for further body specifications):

1. No raised or gurney lips of any type allowed on body.
2. All body panels must be solid. No holes, slots, or air gaps are permitted. NACA ducts or NACA style ducts are not permitted. One hole for interior (deck) mounted oil cooler is permitted.
3. Cars must have full fender tops on both sides.
4. The minimum ground clearance will be 3".
5. No wings or tunneling of any type allowed underneath body or chassis, along frame, or around fuel cell area.
6. A stone shield for remote oil filters or transmission is allowed; maximum 24" x 24", located near rear engine plate.
7. Deck height: may be dropped no more than a maximum of 4 inches below the door; and must be enclosed at firewall; will be monitored by Competition Director.
8. All non-approved bodies or any section(s) of the body may be assessed a "minimum" fifty-pound (50-lb) weight penalty at the discretion of Competition Director or not permitted to compete.

Nose Piece:

1. Only approved nosepieces will be permitted. A list of approved manufactures and part numbers for competition are as follows:
 - Dominator
 - MD3 – Performance Bodies
 - ARP Air Speed nose
 - Five-Star MD3 type
 - Performance Bodies/Five Star MD3 2015
 - Performance Bodies / Five Star 2016 Evolution
 - Performance Bodies / Five Star 2018 Evolution 2
2. Approved nose assemblies must be installed per the manufactures instructions. All nose assemblies must meet the maximum/minimum dimensions, shall maintain manufacture appearance and not be altered.
3. All nosepieces must be made of molded type material.
4. Nose filler panel shall be flat across to entire surface, dishing or raising prohibited.
5. Two-piece noses must be positively fastened together in the center. Spacers added to gain width will not be permitted.
6. The nosepiece must be mounted in a manner that does not alter its original shape.
7. The nose shall remain flat; no wicker bill. Alterations and/or additions may not be made to this area other than cooling holes. A maximum of three two inch holes may be drilled into the nose for the sole purpose of air flow for engine cooling purposes. No ducts of any type will be allowed.
8. The nosepiece can extend a maximum of 54" from the center of the front hub to the farthest point extending forward.

Roof:

1. The roof length from front-to-back must be a minimum of 44" with a maximum of 54".
2. The roof width from side-to-side must be a minimum of 48" to a maximum of 52".
3. The roof must be stock appearing and be mounted level to the body on chassis manufacturers roof tabs. no shims/spacers.
4. The minimum height of the roof will be 45" with a maximum height of 50" measured from the ground.
5. The roof must be mounted parallel to the body and near the center of the car as viewed from the front of the car.
6. A maximum 1-1/2" roll, turned downward will be permitted along the front edge of the roof. A maximum 1"-inch roll, turned downward, will be permitted along the rear edge of the roof. These modifications will be permitted to improve the strength of the roof. Any other modifications to the roof will not be permitted.
7. Flat and/or odd shaped roofs will not be permitted. Bellied and hollowed roofs will not be permitted.
8. Any sun/antiglare shields may not exceed a 4" drop from the top roof line, and must hinge for easy exiting.
9. A maximum of two (2) roof edge bead rolls of a maximum height of 1/2"-inch the length of the roof will be permitted.
10. Only single plated roofs will be permitted.
11. The maximum thickness of the roof at any point will be 1/2".
12. The roll cage and associated frame members above the interior panels (decking) must remain open. Enclosures will not be permitted.

Roof Supports/Window Side Panels:

1. The front roof supports must extend forward to the rear of the hood.
2. All roof side panels must extend to the edge of the bodies

3. Roof supports or "C" pillars on both sides must be made of equal material.
4. Window openings are allowed, but must be the same opening on left and ride side; must match.
5. If clear lexan window is used, it must be used on both sides. Both sides have to be either open, or both sides closed.
6. Curved or arched roof supports allowed. 3" maximum arc allowed at widest point; checked with straight edge, extended from roof edge to door edge.

Doors:

1. The door-to-door measurement must not exceed 78" in width at the top of the doors.
2. The door-to-door measurement must not exceed 90" in width when measured at the bottom of the doors in the center of the car.
3. The measurement from the rear of the top of the deck to the highest point of the right front fender must be a straight line that must be within 1 inch when a straight edge or string is installed on the racecar the entire surface of the body must be within 1 inch of the plane.
4. **Doors must be flat** or may have a slight outward body roll; no doors or body panels allowed to be rolled or curved inward. Hollow and/or bellied doors will not be permitted.
5. The minimum ground clearance will be 3"-inches.

Quarter Panels:

1. The maximum distance from the center of the rear hub to the top quarter of the panel is 54".
2. The quarter panels must not exceed 78" in width at any point as measured at the top of the panels.
3. The maximum width for the quarter panels measured from outside-to-outside and/or at the bottom of the quarter panel will be 86".
4. Any breaks and/or bends formed in the sides of the quarter panel that move the panel toward the center of the car will not be permitted.
5. The maximum distance from the center of the rear hub to the rear trailing edge of the quarter panel will be 50".
6. The maximum height from the ground to the top of the rear deck at the top of the rear quarter panel is 38".
7. Skirting that extends behind the rear quarter panel will not be permitted.

Spoiler (See spoiler diagram at the end of Rulebook for further spoiler specifications):

1. The rear spoiler must begin at the rear most point of the quarter panels.
1. Maximum overall height of the rear spoiler will be 8"-inches; the maximum width of the real spoiler including braces and/or supports is 72"-inches.
2. The rear spoiler must begin at the deck and extend 8"-inches from that point. Suspending the spoiler to create a wing type device will not be permitted.
3. Spoilers must be made of a solid material such as lexan, sheet aluminum, or materials of equal strength. Spoiler and spoiler supports should be made of equal material on all areas. No open spoiler supports. Spoiler height, width, and angle must be the same at all times for the entire area of the spoiler. No varying spoiler heights or spoiler angles. (See spoiler diagram)
4. Only three spoiler supports will be permitted. The front edge of the spoiler brace/support must be in line with the spoiler.

5. The measurement of the spoiler is a total of all material including any turns, up or down, and includes support brace. Spoiler must meet template with one single break.
6. All specifications on body diagram are measurements above the deck. Be sure to allow 1" to 1 ½" along lower edge to break for mounting purposes. Bottom corner of spoiler support should not extend past rear corner of deck.

TRACTION CONTROL/RADIO/TRANSMISSION DEVICES:

1. All Traction Control Devices are strictly prohibited during any form or portion of a RUSH Series sanctioned event, race or practice/test session.
2. All traction control devices, whether electronically controlled in the ignition system, wheel sensors or any means of measuring ground speed to control wheel spin, are strictly prohibited. All devices not mentioned in the above that are found to control wheel spin, timing or fuel delivery control will be considered strictly prohibited.
3. At NO time will there be any type of ping control devices, remote devices that modify RPM and/or timing, automated throttle controls, timing controls, or any modifications to the ignition control boxes, distributors, or any other part of the Ignition System. This includes any add on component or components inside or outside the cockpit of any competitor's race car. There shall be NO driver controlled wheel spin, timing or fuel delivery control devices in the cockpit area of any race car. Remote control components utilized to affect and/or control wheel spin, timing or fuel will not be permitted.
4. Adjustable restrictor plates will not be permitted.
5. Radios and/or devices transmitting voice and/or data will not be permitted.
6. Data acquisition systems will not be permitted.
7. A competitor found with any of the devices mentioned under Traction Control/Radio/Transmission Devices, #1-6, will be disqualified from the event (loss of points and monies), forfeit the device permanently and the following:
 - First Offense: \$500 fine & 30-day suspension from any RUSH-sanctioned event plus any testing costs, if required
 - Second Offense: \$1,000 fine & 90-day suspension from any RUSH-sanctioned event plus any testing costs, if required
 - Third Offense: \$2,000 fine & 365-day suspension from any RUSH-sanctioned event plus any testing costs, if required
9. A competitor refusing to relinquish any of the above mentioned will result in disqualification from the event (loss of points and monies) and "refusal of tech" penalties.
10. GPS and/or any other type of electronic tracking and/or locating device will not be permitted for any reason. If found, driver and car will be disqualified for the night (loss of points and monies), and will forfeit device permanently.
11. GoPro and/or similar camera devices are permitted providing they do not interface with the car, electronic or otherwise, and do not transmit any signals. Cameras not meeting specifications, will result in driver and car being disqualified for the night (loss of points and monies), and will forfeit device permanently.

DRIVER RADIOS/TRANSPONDERS:

NO radios other than one-way communications between Track and/or Series Officials. One-way driver radio is mandatory at all Tour events and may be mandatory at Weekly events (see each track's rules). Transponders are mandatory at tracks and events that require them (see each track's rules or Touring procedures for more info).

PERSONAL SAFETY EQUIPMENT:

General

1. Each competitor is solely responsible for the effectiveness and proper installation, per the manufacturer's specifications, of personal safety equipment and determining it to be adequate for competition at every event. Each competitor is expected to investigate and educate themselves for continuing improvement regarding their own personal safety equipment.
2. RUSH Rules regarding safety equipment are the minimum and you will not be permitted to compete if your safety equipment does not meet the RUSH rules. Many tracks and or states require additional safety equipment not mandated by RUSH. Be sure to familiarize yourself with the requirements of each track. RUSH-sanctioned tracks and/or any track hosting a RUSH event will be required to enforce the RUSH safety rules completely without exception.
3. Each car will be equipped with minimum of an SFI 16.5 or SFI 16.1 approved restraint system, until the date of the belt expiration (two years from the date of manufacturer). Seat belt restraint systems shall be installed and used in accordance with manufacturer's instructions. In any type of manufacturer's installation the fasteners should be magnetic steel unless using type of mount in which the seat belt wraps around the roll cage.
4. Seat belt material should not be permitted to come in contact with any sharp or metal edge, including when the material passes through the seat.
5. Rolled and/or deburred and/or flanged edges or anywhere seat belt webbing passes through and may come in contact with abrasive edges are recommended.

Protective Clothing

1. All drivers will be required to wear a fire resistant driving uniform meeting minimum of the SFI 3.2A/5 specification and display a valid SFI 3.2A/5 label.
2. All drivers should wear fire resistant accessories including but not limited to; head sock, under garments, shoes, and socks. All drivers are required to wear fire resistant gloves. Shoes and gloves will be required to meet minimum of the SFI 3.3 specifications and display a valid SFI 3.3 label.

Seats

1. Aluminum and/or carbon fiber-type composite seats only will be permitted. If a carbon fiber-type composite seat is used it must meet the SFI 39.2 ratings. Aluminum seats with an FIA and/or SFI 39.2 rating are recommended. All seats must be mounted to the frame as required by the seat and chassis manufacturer. Full containment seat(s) and/or aftermarket bolt on head restraints are recommended.
2. All areas surrounding the head should have padding.
3. A right side head restraint net and/or support is recommended. All head restraint nets should be equipped with quick release mechanisms.

Effective 2019:

Seats must be "Full Containment" style effective January 1, 2019, constructed of aluminum to the general design specifications of current industry standards, (SFI 39.2 highly recommended). Design shall include comprehensive head surround, shoulder and torso support system, energy impact foam, and removable head foam. Consult with your seat manufacturer for questions and recommendations regarding your seat safety system.

Seats manufactured using carbon fiber or composite materials must meet SFI 39.2 specifications.

Up-fitting an existing seat with bolt-on kits will be permitted with a seat manufacturer-produced kit and an acceptable base seat approved by the seat manufacturer. Consult with your seat manufacturer for recommendations regarding your current seat. If Left Head Surround does not exceed 7 inches from the back of the headrest, a left side seat net meeting SFI specifications is required.

Helmets

1. All drivers must wear a full-face helmet with a minimum safety rating of FIA 8860-2010, Snell SA 2015, Snell SA 2010, Snell SAH 2010, and/or a valid SFI 31.1/2005 label.
2. It is recommended that helmets should be fitted with the Eject™ helmet removal system.
3. Head and Neck restraints are strongly recommended. The head and neck restraint system must be mounted and connected to the helmet per the helmet manufacturer and head and neck manufacturer instructions.
4. Arm restraints are recommended and must be connected and used as instructed by the manufacturer.

Effective 2019:

Head and neck restraints will be mandatory effective January 1, 2019 and must be SFI 38.1 approved and display a legible and valid SFI 38.1 label.

Other Recommended

1. It is highly recommended all teams must have a fire extinguisher in the rear of their transporter with the car number clearly visible on the extinguisher. It is highly recommended the fire extinguisher be a minimum of 20lbs and is recommended to FFF type chemical and/or Dupont FE-36 and/or equivalent.

GENERAL CAR INSPECTION:

All cars may be subject to technical inspection at any time. Any driver that fails to cooperate and/or allow an inspection of his car at any time will be subject to disqualification, a 45-day suspension, and \$750 fine.

Rear car covers are permitted, but must be removed prior to leaving pit stalls. No covers of any kind under the car or covering wheel openings. Each team will receive one (1) verbal warning for the season. A second infraction will result in a loss of warm-ups, a loss of a qualifying lap, or placement to the tail of your next scheduled event, depending upon when said second infraction occurs.

FINES, PENALTIES, SUSPENSIONS & APPEALS

PRE-RACE TECHNICAL VIOLATION:

If a technical violation(s) is found during pre-race technical inspection, the driver/team will be advised of the violation and must meet full compliance before being allowed to compete.

REFUSAL OF TECH

A refusal of tech and/or failure to allow an official to confiscate a part(s), other than the already previously stated individual refusal penalties/suspensions, will result in a 45-day suspension and \$750 fine. All illegal parts will be confiscated.

FINES & PENALTIES:

If an entrant is disqualified for any reason, any fine and /or suspension applies to both the driver and car owner if not the same person. In other words, if an entrant is disqualified for a technical violation, such as an engine not in compliance with tech specs, neither the owner nor the driver can race for the suspension period, and while only one fine will be charged, neither party can race until that fine is paid. Fine must be paid in full to Series by cash or certified check in order to compete once suspension period ends. NOTE: If suspension includes 'a number of days' clause and occurs at the end of the season when no additional events exist, suspension will carry over to the following year beginning with the first RUSH-sanctioned event in the region.

EVENT SUSPENSIONS:

Driver/Owner suspended for any infraction will carry over to **ALL** RUSH-sanctioned divisions and will preclude driver/owner from competing at **ANY** RUSH-sanctioned event until suspension is lifted.

MULTIPLE INFRACTIONS:

In the event driver and/or car is disqualified in post-race tech for the same technical rules infraction twice (excluding engines within the sealing system, tires, fuel, and shocks, springs, suspensions rules- see each rule for specific penalties), driver and car will be suspended for 7 days from all RUSH-sanctioned events. Each successive infraction will carry an additional 7-day suspension.

In the event an entrant fails technical inspection for multiple infractions that each carry a suspension and/or fine at the same event, suspension and/or fine will compound and accumulate with each infraction.

LEGALITY OF PARTS:

If RUSH or Track Tech Inspector is unsure of the legality of a part, said part will be sent to GM or to RUSH Office for inspection. At this time, finishing position will be frozen until legality of said part is determined. In the event of a disqualification, finishing position, points and monies would be adjusted accordingly. **ALL ILLEGAL PARTS WILL BE CONFISCATED & DESTROYED!** Not allowing confiscating of parts is considered "cheating within the bolts" and said penalties will be imposed.

APPEALS PROCESS:

RUSH will determine any and all suspensions/fines that are covered in the rules and any violation that may come up during the year. RUSH will make judgment on the sanctions, and violator(s) will be sent official notice by a certified letter, return receipt requested.

Driver and/or car owner has the opportunity to appeal his or her sanction and must do so in writing accompanied by any relevant documentation. Appeal must be in writing and faxed or e-mailed to the RUSH Office at 724-964-0604 or within 48 hours of notification of violation.

RUSH will then set a date and time for the appeal hearing at the business office located at the address of 4368 Route 422, Pulaski, PA 16143. The violator(s) will present his/her case to the RUSH Racing Series. The violator(s) and one other person is permitted to attend the appeal hearing. Additional attendees must be approved by RUSH pursuant to a written request.

Following the appeal hearing with the violator(s), RUSH may conduct further follow-ups, meetings, etc. with any other necessary party(s). Judgment will then be rendered to the violator by a certified letter, return receipt.

Violator(s) agrees that the decision made will be final and party posting appeal has no legal rights thereafter. In the event of a protest, the party that protested also agrees to accept final ruling on decision and has no legal rights thereafter.

All body components 3" Min. above ground.
All body measurements are maximum unless otherwise specified.

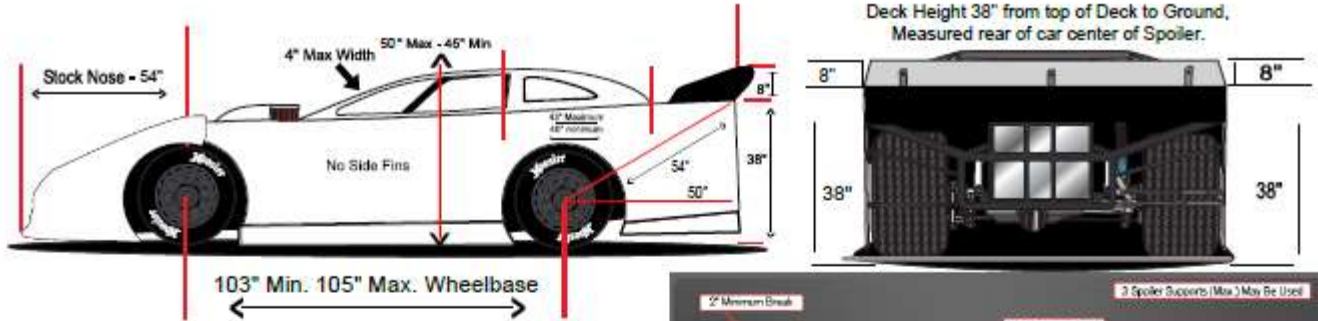

15" Min.
17" Max

*Rush Dirt Late Model Series
Spoiler Support Dimensions*

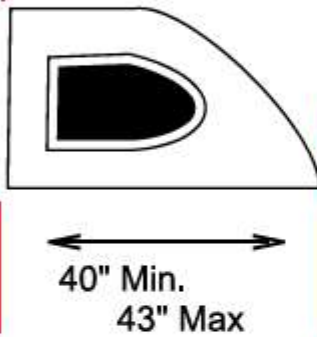

2" Min. spacing

The Measurement of the spoiler is a total of all material including any turns, up or down, and includes support brace. Spoiler must meet template with 1 single break.

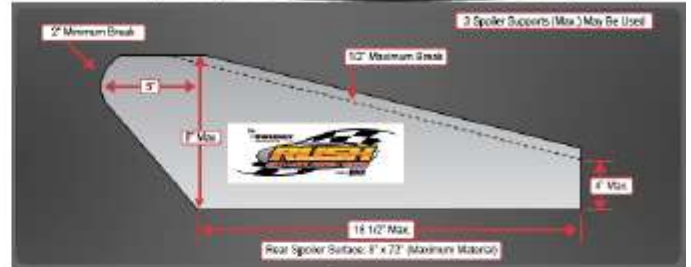

All specifications here are measurements above the deck. Be sure to allow 1" - 1 1/2" along lower edge to break for mounting purposes. Bottom corner of spoiler support should not extend past rear corner of deck.

Roof Supports

Front Roof Supports 4" Maximum With 12" flare max at bottom.
Rear Roof Supports or "C" Pillars, Window Openings Allowed but must be same size opening on left and right side, and can not be offset. If clear lexan IT MUST BE USED ON BOTH SIDES BOTH SIDES OPEN OR BOTH SIDES CLOSED. CURVED OR ARCED ROOF SUPPORTS ALLOWED, 3" MAXIMUM ARC ALLOWED AT WIDEST POINT, CHECKED WITH STRAIGHT EDGE, EXTENDED FROM ROOF EDGE TO DOOR EDGE.

